

(12) UK Patent Application (19) GB (11) 2 233 499 (13) A

(43) Date of A publication 09.01.1991

(21) Application No 9013635.9

(22) Date of filing 19.06.1990

(30) Priority data

(31) 01166052 (32) 28.06.1989 (33) JP
01174581 06.07.1989
02066649 16.03.1990

(51) INT CL⁵
H01H 13/52

(52) UK CL (Edition K)
H1N NUJB N448 N618 N625 N649 N652 N700
N705 N717 N854
H1S SBK S6A3 S9A5 S9D1

(56) Documents cited
GB 2180994 A GB 1562264 A EP 0063851 A1

(58) Field of search
UK CL (Edition K) H1N NBH NUJB, H1S SBK
INT CL⁵ H01H

(71) Applicant
Mitsubishi Denki Kabushiki Kaisha
(Incorporated in Japan)

2-3 Marunouchi 2-chome, Chiyoda-ku,
Tokyo, Japan

(72) Inventors
Kiyosi Yagita
Masahisa Kobukuro

(74) Agent and/or Address for Service
Beresford & Co
2-5 Warwiclck Court, High Holborn, London,
WC1R 5DJ, United Kingdom

(54) Switch

(57) A switch comprises a first electrode composed of a non-conductive flexible film (10) having a conductive film (10A) on one surface and a second electrode composed of a non-conductive film (12) having a conductive film (12A) on one surface facing the first electrode and a plurality of insulative spacers (14) mounted on at least one of the electrodes. The spacers (14) are of very small dimension - lateral dimensions of 50 μm or less and a height of 15 μm or less, whereby the insensitive zone areas of the switch are of reduced size. The spacers (14) may be formed from a photoresist. A protective coating of plastics containing metal or metal oxide particles may be formed upon the conductive film (10A). In a further embodiment, the conductive films (10A, 12A) are coated with resistance layers of plastics containing metal or metal oxide particles and metal coated transparent balls of 5-10 μm diameter.

FIG. 1

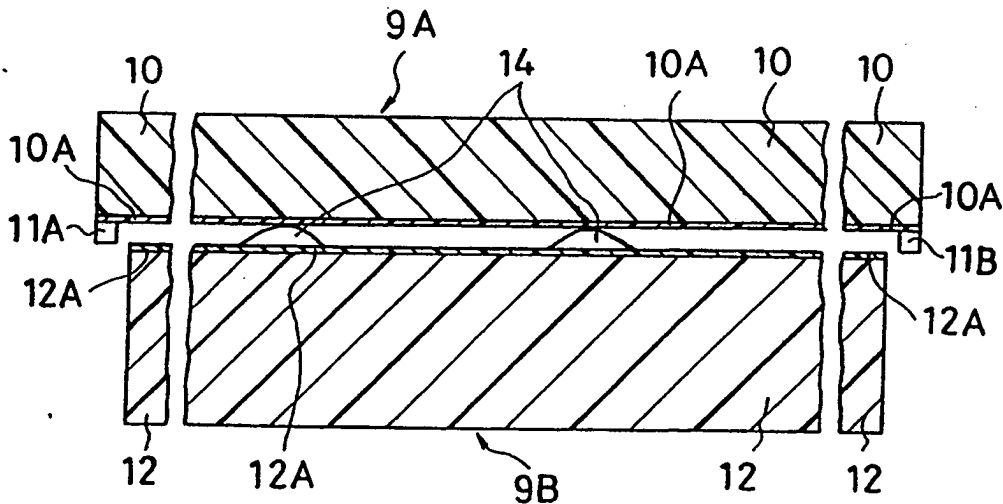

GB 2 233 499 A

1/9

FIG. 1

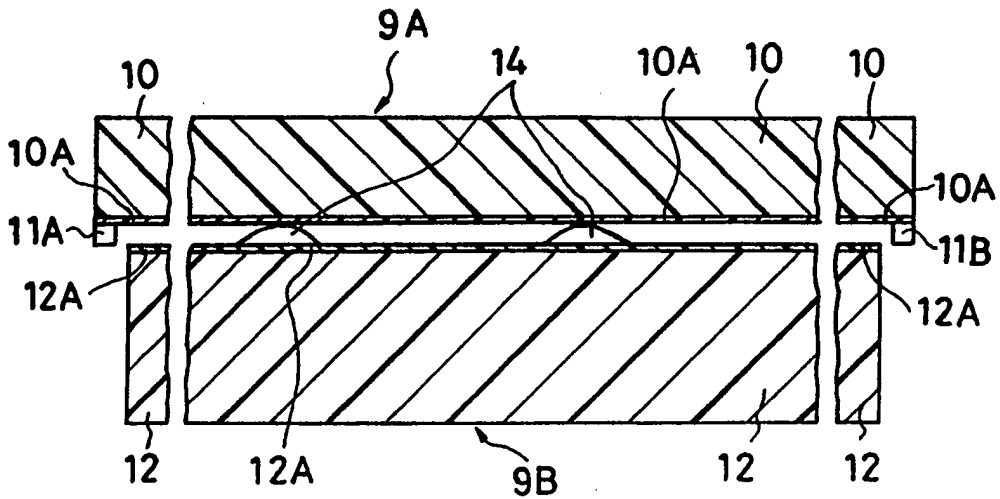

FIG. 2

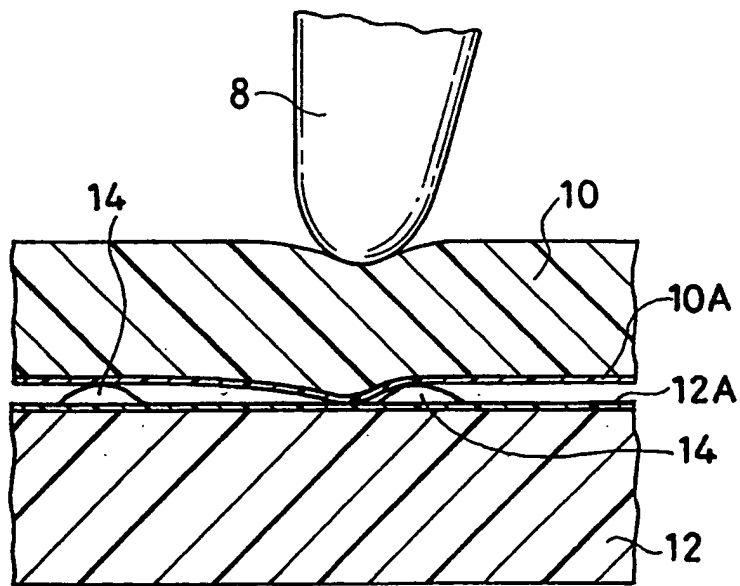

FIG. 4

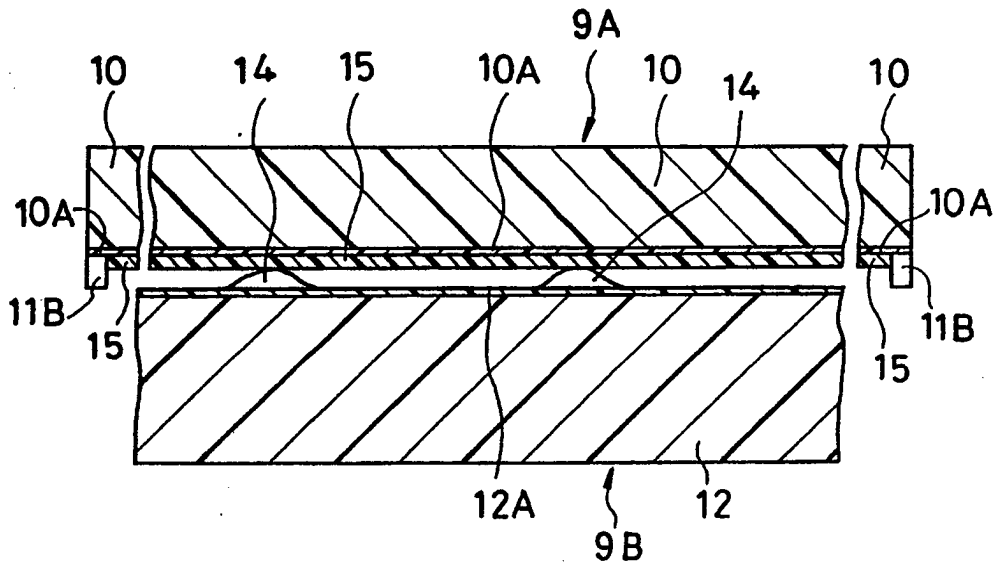

FIG. 5

4/9

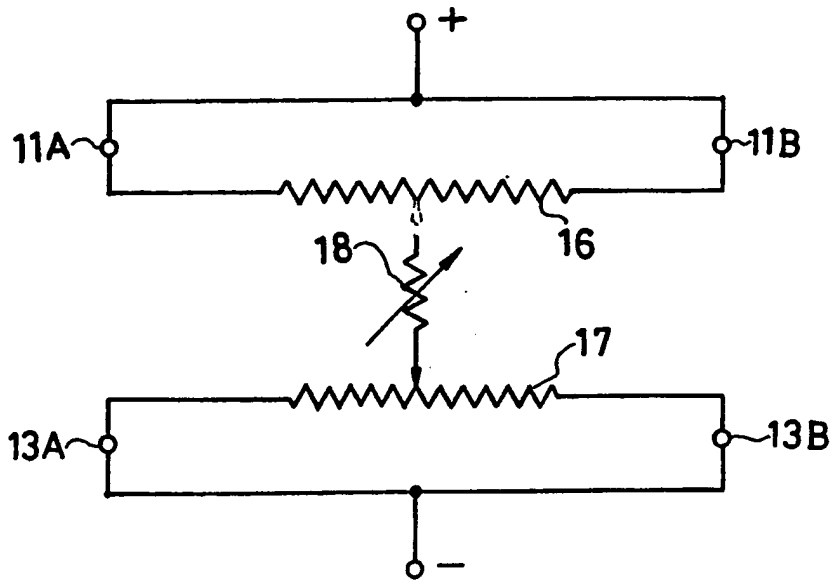

FIG. 6

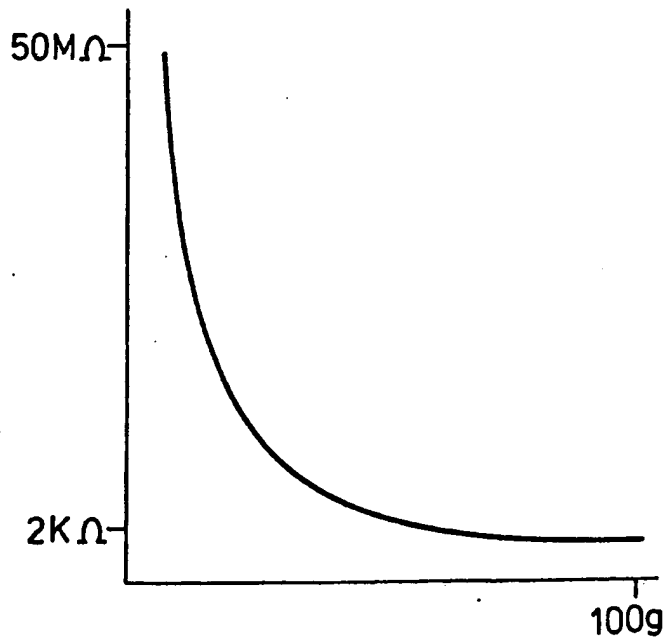

FIG. 7

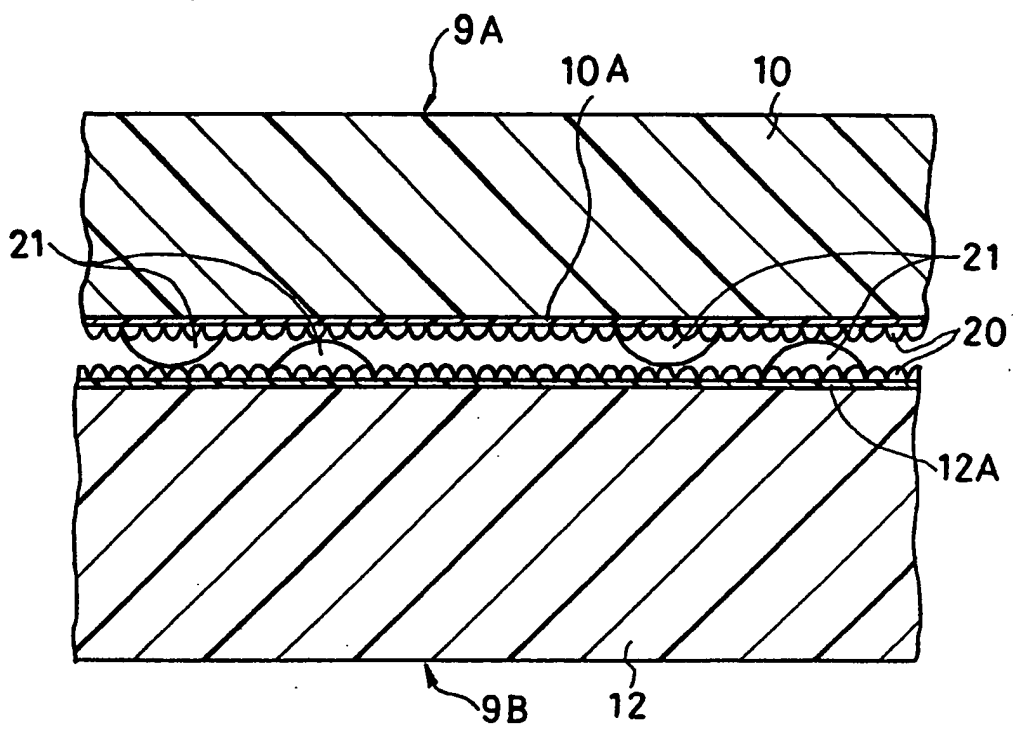
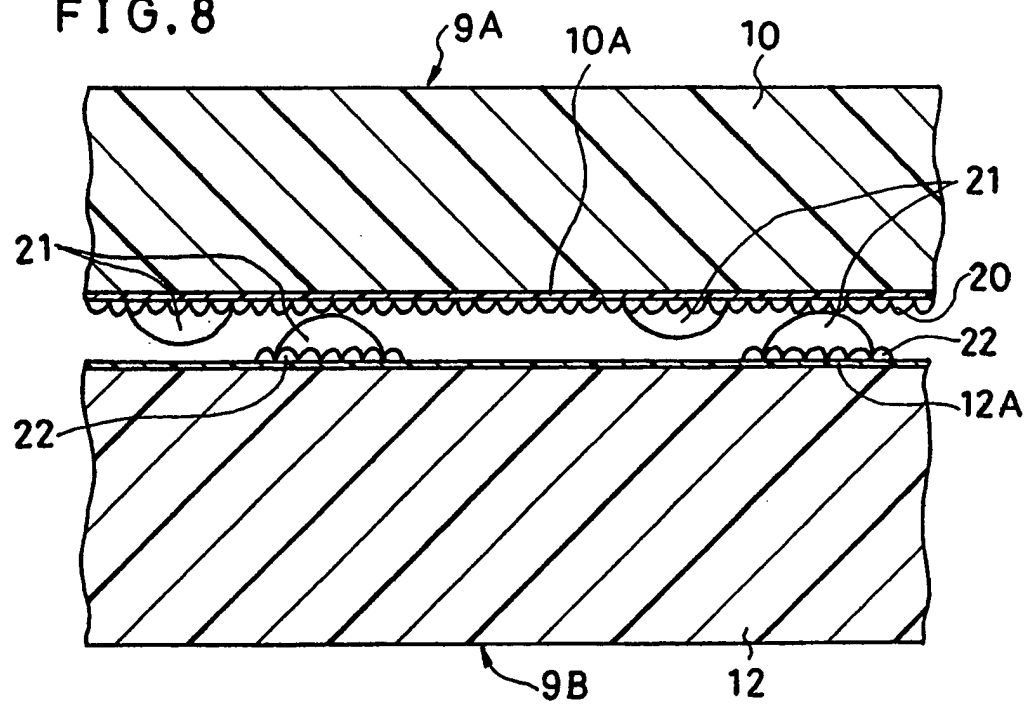
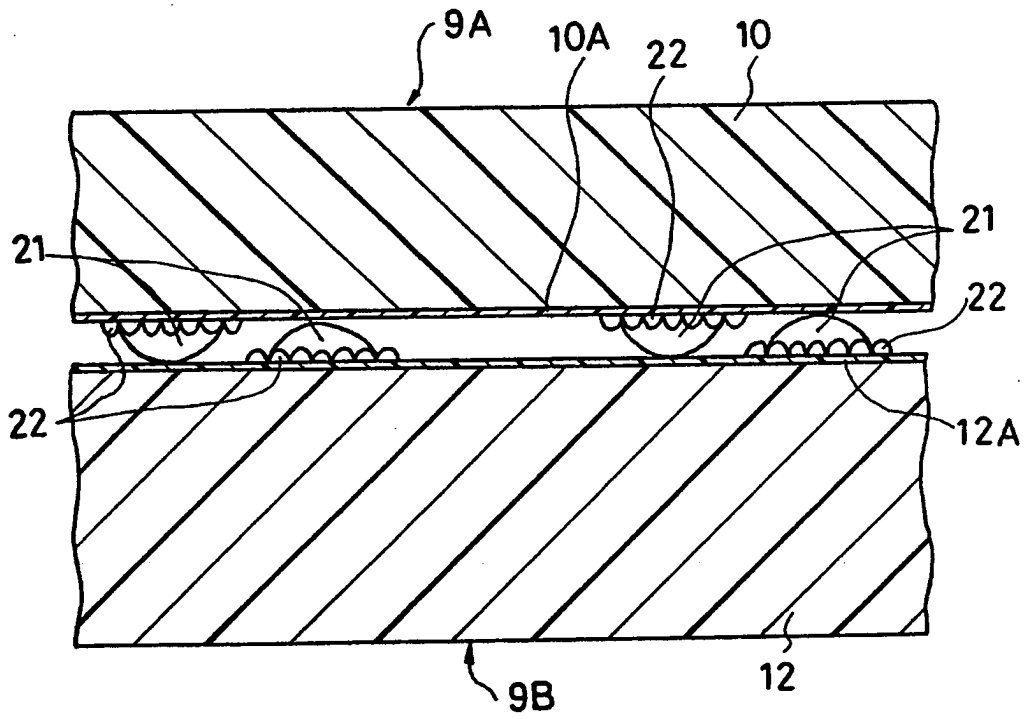

FIG. 8



6/9

FIG. 9



7/9

FIG.10 (Prior Art)

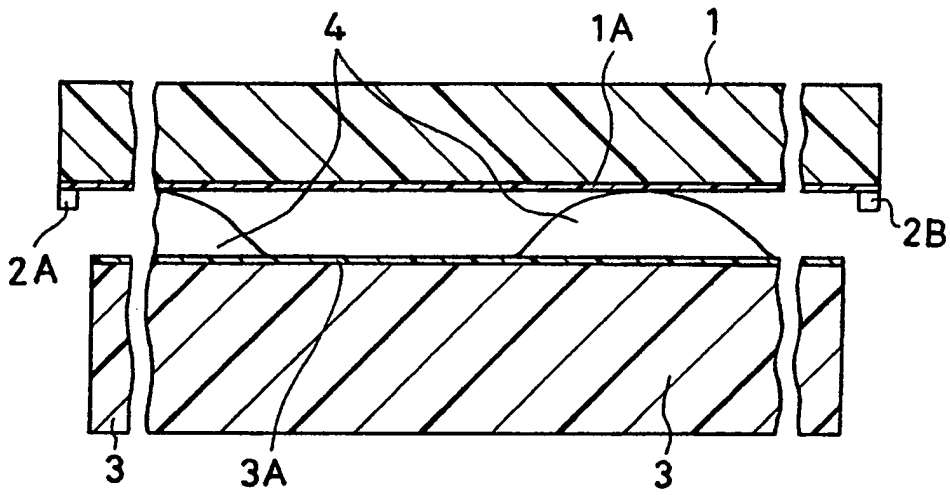
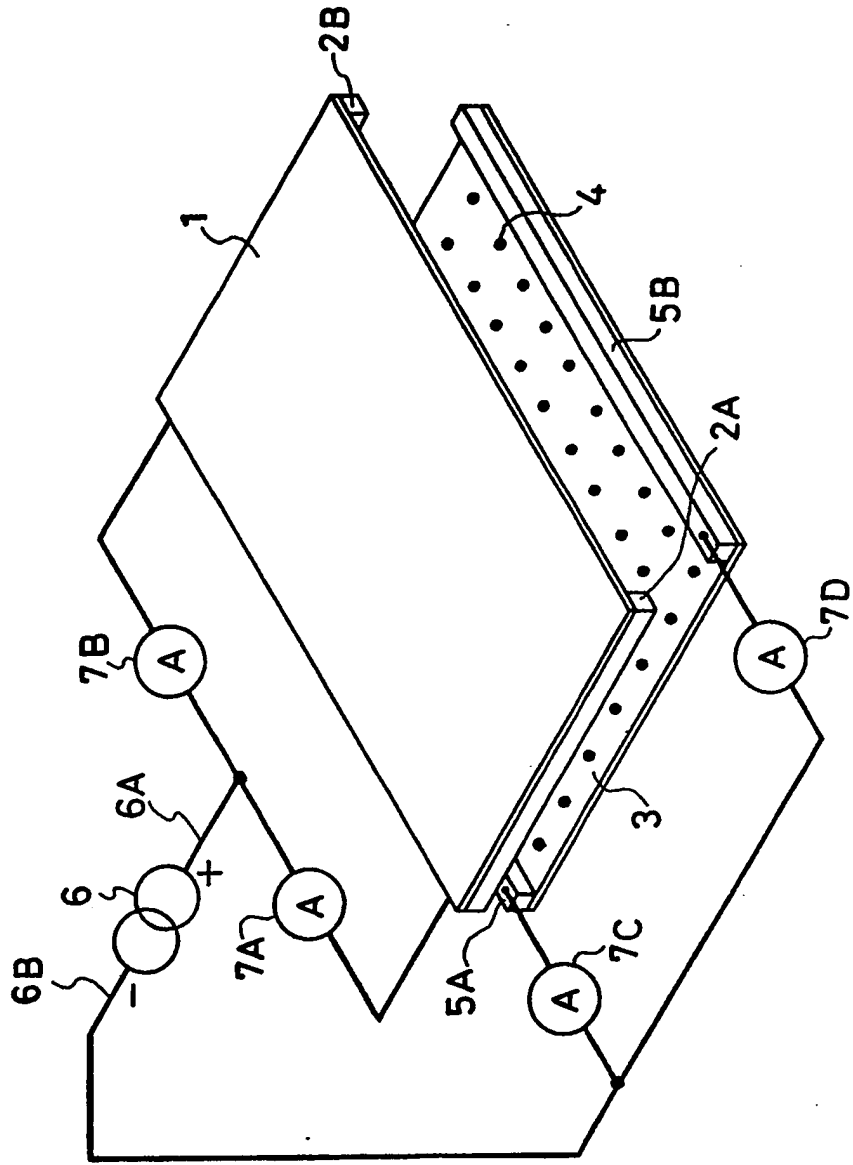
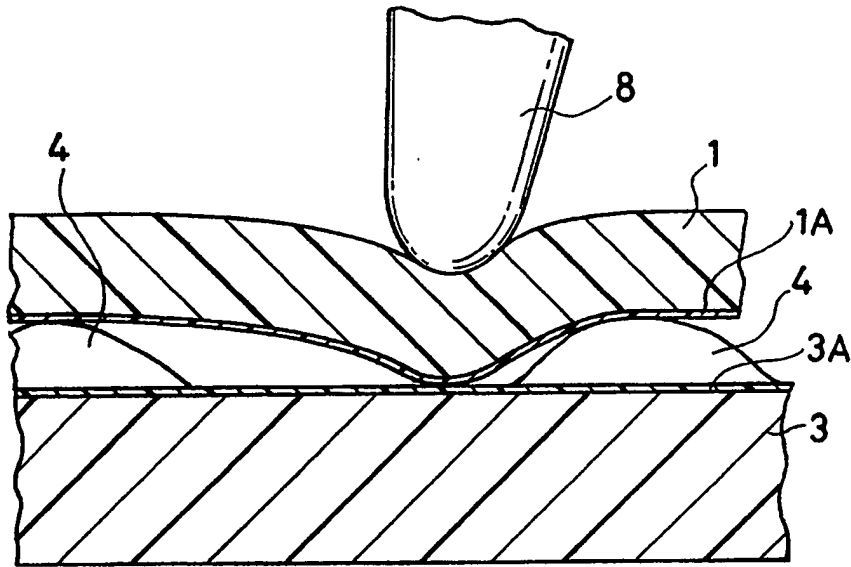

FIG.11 (Prior Art)



9/9

FIG. 12 (Prior Art)



TITLE OF THE INVENTION

Sheet-like switch

FIELD OF THE INVENTION AND RELATED ART STATEMENT

1. FIELD OF THE INVENTION

The present invention relates generally to a sheet-like switch, and more particularly to a sheet-like switch which is activated by pushing the surface of the sheet-like switch with a sharp-pointed member such as a ball-point pen.

2. DESCRIPTION OF THE RELATED ART

An example of a conventional sheet-like switch is shown in "Nyuryoku-sohchi kaihatsu, sekkei, ohyo no yoten" ("The point of research, design, application of an input equipment" Page 170) which is published by Japan Industry Engineering Center.

The configuration of the conventional sheet-like switch is shown in FIG.10. Referring to FIG.10, a transparent and flexible first non-conductive film 1 has a transparent conductive film 1A of a thin metal film or a metal oxide film on one surface thereof, and terminals 2A and 2B which are connected to the conductive film 1A at both end parts are mounted on the first non-conductive film 1. A second non-conductive film 3 is provided to face to the surface of the conductive film 1A of the first non-conductive film 1. The second non-conductive film 3 is preferable to be made of a transparent hard glass

(

plate, for example. A transparent conductive film 3A is formed on the second non-conductive film 3, and the surface of the conductive film 3A is faced to the first non-conductive film 1. As shown in FIG.11, terminals 5A and 5B are mounted on both end parts of the conductive film 3A.

A plurality of substantially hemispherical spacers 4 which are made of non-conductive material are arranged in two-dimensional way on the surface of the conductive film 3A with predetermined intervals between each other. The spacers 4 are formed by mean of a screen printing, and the diameter thereof is 150 --- 500 μm and the height thereof is 15 --- 50 μm . The first non-conductive film 1 is held retaining a predetermined interval to the second non-conductive film 3 by the above-mentioned spacers 4, and the conductive films 1A and 3A are spaced apart from each other.

FIG.11 is a perspective view of a configuration in operation of the conventional sheet-like switch. The positive terminal 6A of a constant current power source 6 is coupled to the terminal 2A through a current detecting apparatus 7A, and the positive terminal 6A is also coupled to the terminal 2B through a current detecting apparatus 7B. The negative terminal 6B of the power source 6 is coupled to the terminal 5A through a current detecting apparatus 7C, and the negative terminal 6B is also coupled

to the terminal 5B through a current detecting apparatus 7D. As shown in FIG.11, the terminals 2A and 2B are orthogonally aligned to the terminals 5A and 5B. Referring to FIG.11, though the first non-conductive film 1 is illustrated with a considerable distance from the second non-conductive film 3, in the actual sheet-like switch, the first non-conductive film 1 contacts with the second non-conductive film 3 at every spacers 4, as shown in FIG.10.

As shown in FIG.12, when the surface of the first non-conductive film 1 is pressed with a sharp-pointed member 8 such as a ball-point pen, the first non-conductive film 1 is bent down, and the conductive film 1A contacts the conductive film 3A of the second non-conductive film 3. Consequently, a current path is formed between the conductive films 1A and 3A. In the circuit of FIG.11, a current which flows from the positive terminal 6A to the negative terminal 6B of the power source 6 through the terminals 2A and 2B, conductive film 1A, conductive film 3A and terminals 5A and 5B is detected by four current-detecting apparatuses 7A, 7B, 7C and 7D. A position on which the conductive film 1A contacts the conductive film 3A is calculated on the basis of detected currents of the respective current-detecting apparatus 7A, 7B, 7C and 7D. The X-coordinate and Y-coordinate of the position are given by

$$X = \frac{i_2}{I} \times a, \quad Y = \frac{i_4}{I} \times b$$

$$(I = i_1 + i_2 = i_3 + i_4)$$

where, a: a distance between the terminals 2A and 2B,

b: a distance between the terminals 5A and 5B,

I: entire current,

i1: a detected current of the current detecting apparatus 7A,

i2: a detected current of the current detecting apparatus 7B,

i3: a detected current of the current detecting apparatus 7C, and

i4: a detected current of the current detecting apparatus 7D.

In the above-mentioned prior art example, though the constant current power source is used as the power source 6, a constant voltage power source is usable as the power source 6, and the position is calculated in a similar manner to that described above.

In the prior art mentioned above, the diameter of the spacers 4 is 150 --- 500 μm and the height thereof is 15 --- 50 μm . Since the spacers 4 are formed by means of the screen printing, it is difficult to form smaller spacers 4 than the sizes mentioned above.

Hence, in the sheet-like switch of the prior art, the conductive film 1A can not be contacted the

conductive film 3A within a diameter of 500 --- 1500 μ m of the circumferential zone of the spacer 4 by pressing the first non-conductive film 1 with the sharp-pointed member 8. The zone is called as an "insensitive zone". Since there is no switch function in the insensitive zone, detection of position is impossible.

OBJECT AND SUMMARY OF THE INVENTION

An object of the present invention is to provide a sheet-like switch which is provided with small-sized spacers between both non-conductive films.

The sheet-like switch in accordance with the present invention comprises:

a first sheet-like electrode composed of a non-conductive flexible film having a conductive film on a surface thereof,

a second sheet-like electrode composed of a non-conductive film having a conductive film on a surface thereof and faced said surface having said conductive film to said first sheet-like electrode, and

a plurality of non-conductive spacers of 50 μ m and below in diameter and 15 μ m and below in height mounted on said conductive film of at least one of said first and second sheet-like electrodes.

While the novel features of the invention are set forth particularly in the appended claims, the invention, both as to organization and content, will be

(better understood and appreciated, along with other objects and features thereof, from the following detailed description taken in conjunction with the drawings.

BRIEF DESCRIPTION OF THE DRAWINGS

FIG.1 is a sectional partial side view of a first embodiment of a sheet-like switch in accordance with the present invention;

FIG.2 is a sectional partial side view in operation of the sheet-like switch in the first embodiment;

FIG.3 is a perspective view of connection of the sheet-like switch of the present invention;

FIG.4 is a sectional partial side view of a second embodiment of the sheet-like switch in accordance with the present invention;

FIG.5 is an equivalent circuit diagram of the sheet-like switch shown in FIG.3;

FIG.6 is a graph of a pressure-sensitive characteristic of the sheet-like switch of the second embodiment;

FIG.7 is a sectional partial side view of a third embodiment of the sheet-like switch in accordance with the present invention;

FIG.8 is a sectional partial side view of a fourth embodiment of the sheet-like switch in accordance with the present invention;

FIG.9 is a sectional partial side view of a fifth embodiment of the sheet-like switch in accordance with the present invention;

FIG.10 is the sectional partial side view of the sheet-like switch in the prior art;

FIG.11 is the circuit of the sheet-like switch in the prior art;

FIG.12 is the partial side view in operation of the sheet-like switch in the prior art.

It will be recognized that some or all of the Figures are schematic representations for purposes of illustration and do not necessarily depict the actual relative sizes or locations of the elements shown.

DESCRIPTION OF THE PREFERRED EMBODIMENTS

FIG.1 is a sectional partial side view of a first embodiment of a sheet-like switch in accordance with the present invention. Referring to FIG.1, a first electrode 9A is composed of a first non-conductive film 10 of a flexible and transparent plastic film or a glass plate (Most generally polyester is used.) on which a transparent conductive film 10A is formed on one surface thereof. The conductive film 10A is a thin film of about 1000 Å thick of gold, nickel, palladium, chrome, tin oxide, indium-tin oxide, tin or iodine copper, for example.

The conductive film 10A is provided with terminals 11A and 11B on both end parts thereof.

(A second electrode 9B faces to the surface of the conductive film 10A of the first non-conductive film 10. The second electrode 9B is composed of a second non-conductive film 12 on which a conductive film 12A is formed on one surface thereof, and the surface having the conductive film 12A is faced to the conductive film 10A of the first non-conductive film 10. The conductive film 12A is a metal thin film or a metal oxide film which is made of a similar materials of the conductive film 10A. The second non-conductive film 12 is generally made of hard plastic plate or glass plate. Preferably the first and second non-conductive films 10 and 12 are transparent in general use, but an opaque non-conductive film is usable in specialized use.

A plurality of spacers 14 are placed on the surface of the conductive film 12A with a predetermined interval. The spacers 14 are formed on the conductive film 12A by the process described hereafter. First, a photoresist which is an optical sensitive plastics is coated on the surface of the conductive film 12A, and then the photoresist is exposed to light through a mask having a pattern for leaving the parts of the spacers 14. Subsequently, the photoresist is etched away except for the parts corresponding to the spacers 14 by mean of a chemical process.

The spacers 14 are 50 μ m and below in diameter

and are 15 μm and below in height, for example, and are hemispherical, cylindrical, cubic, cone-shaped and the like in shape. The spacer 14 is disposed on the entire surface of the second electrode 9B with a predetermined interval. The spacer 14 is enough to be mounted on one of the first and second electrodes 9A and 9B. Terminals 13A and 13B are also disposed on both end parts of the conductive film 12A in a like manner to the conductive film 10A as shown in FIG.3.

In operation of the embodiment sheet-like switch in accordance with the present invention, as shown in FIG.3, the first and second electrodes 9A and 9B are assembled in a manner that the terminals 11A and 11B are perpendicular to the terminals 13A and 13B. The positive terminal 6A of a constant-current power source 6 is coupled to the terminal 11A through a current detecting apparatus 7A, and the positive terminal 6A is also coupled to the terminal 11B through a current detecting apparatus 7B. The negative terminal 6B of the power source 6 is coupled to the terminal 13A through a current detecting apparatus 7C, and the negative terminal 6B is also coupled to the terminal 13B through a current detecting apparatus 7D.

In operation of the sheet-like switch, as shown in FIG.2, the surface of the first non-conductive film 10 is pressed with a sharp-pointed member 8 such as a ball-

point pen. Consequently, the first non-conductive film 10 is bent down, and the conductive film 10A contacts the conductive film 12A. The method for detecting a position pressed with the sharp-pointed member 8 is identical with that described in "Description of the Related Art".

In the first embodiment in accordance with the present invention, the diameter of the spacer 14 is 50 μm and below and the height thereof is 15 μm and below. These size are much smaller than the spacer 4 in the prior art. Hence, area of insensitive zone on the circumference of the spacer 14 is reduced to about 70 μm diameter. Resolution of the position in the first embodiment is 4 -- 5 lines/mm. The first non-conductive film 10 can be made of a flexible glass sheet of 0.2 mm and below thick.

FIG.4 is a sectional partial side view of a second embodiment of a sheet-like switch in accordance with the present invention. In the second embodiment, a conductive coating 15 is provided on the conductive film 10A of the first electrode 9A. The conductive coating 15 functions as a protective coating of the conductive film 10A, and plastics of a kind of polyester, epoxy or acryl containing fine particles of metal or metal oxide which is similar to that of the conductive film 10A is coated on the surface of the conductive film 10A with a uniform thickness. The surface resistivity of the conductive coating 15 is 10^3 --- 10^{10} Ω/cm^2 . The configuration of the

second electrode 9B is identical with that of the first embodiment.

FIG.5 is an equivalent circuit of the sheet-like switch of the second embodiment as shown in FIG.4.

Referring to FIG.5, a resistor 16 represents the conductive film 10A, and a resistor 17 represents the conductive film 12A. A variable resistor 18 represents a resistance of a contact point between the conductive films 10A and 12A.

FIG.6 is a graph of "pressure-sensitive characteristic" which represents variation of the resistance of the variable resistor 18 in variation of the pressure which is applied on the surface of the first non-conductive film 10 with the sharp-pointed member 8 in the second embodiment. As shown in the graph, the resistance decreases from about 50 M Ω to about 2 K Ω in response to increase of the pressure.

In the second embodiment, when the conductive film 10A contacts the conductive film 12A, the conductive coating 15 intermediates therebetween. Therefore, wear of both the conductive film 10A and 12A is prevented. Preferably the conductive coating 15 is a transparent conductive coating which is thinner than 10 μ m. The "surface resistivity" of the conductive coating 15 is preferably $10^3 \Omega/\text{cm}^2$ or more.

A function similar to that described hereinabove

(can be achieved by forming a high-resistance film of about 1 μm thick and a "volume resistivity" of $10^{14} \Omega \cdot \text{cm}$ or more on the conductive film 10A as replacement for the conductive coating 15. In this case, when a pressure is applied between the conductive films 10A and 12A, a resistance between both the conductive films 10A and 12A decreases because of known "Tunnel effect or Schottky effect". The principle of reduction of the resistance is similar to the operation of a semiconductor device, and 5 V or more of D.C. voltage must be applied across both the conductive films 10A and 12A.

The first non-conductive film 10 in the present invention is made preferably of one of glass, polyethylene terephthalate, polyethylene naphthalate, polybutylene terephthalate, polycarbonate, polyethersulfone, polysulfone, epoxy and acryl.

The conductive films 10A and 12A are preferably $10 \text{ --- } 10^4 \Omega/\text{cm}^2$ of surface resistivity and 30 % or more of light transmissivity.

The terminals 11A, 11B, 13A and 13B are made preferably of copper or silver which is relatively lower in resistance.

FIG.7 is a sectional partial side view of a third embodiment of the sheet-like switch in accordance with the present invention. Referring to FIG.7, the first electrode 9A is provided with the conductive film 10A on

one surface of the non-conductive film 10, and moreover, a resistance layer 20 is provided on the conductive film 10A. Additionally, a plurality of spacers 21 are mounted on the resistance layer 20 with a predetermined interval. The surface resistivity of the resistance layer 20 is 10^3 --- 10^{13} Ω/cm^2 , and the thickness thereof is about 10 μm . The resistance layer 20 is formed by coating plastics of a kind of polyester, acryl or epoxy including metal particles or metal oxide particles of 0.1 --- 0.01 μm diameter which is similar to the metal or metal oxide of the conductive film 10A and transparent balls such as glass balls or plastics balls which are 5 --- 10 μm in diameter and which have thin layer of nickel, gold, Ag or the like on the surface. Since the transparent balls are 5 --- 10 μm diameter, convex parts and concave parts of 5 --- 10 μm height are formed on the surface of the resistance layer 20.

The spacers 21 which are mounted on the surface of the resistance layer 20 is made of material and method which are similar to those of the spacers in the first and second embodiments.

In the second electrode 9B, in a similar manner to the first electrode 9A, the resistance layer 20 and spacer 21 are formed on the surface of the conductive film 12A.

In the third embodiment, since the resistance

layer 20 is formed on the surfaces of both the conductive film 10A and 12A, isolation characteristic between the conductive film 10A and 12A is improved. Consequently, the height of spacers 21 can be reduced. When the non-conductive film 10 is pressed with the sharp-pointed member 8, the resistance between the conductive films 10A and 12A decreases in compliance with the pressure-sensitive characteristics shown in FIG.6. Since the resistance layer 20 prevents direct contact between the conductive films 10A and 12A, durabilities of both the conductive films 10A and 12A are improved. Since the spacers 21 are mounted on the convex and concave surface of the resistance layer 20, adherence of the spacers 21 to the resistance layer 20 is improved, and falling of the spacers 21 is prevented.

FIG.8 is a sectional partial side view of a fourth embodiment of the sheet-like switch in accordance with the present invention. Referring to FIG.8, the first electrode 9A in the fourth embodiment is identical with that of the third embodiment shown in FIG.7.

In the fourth embodiment, the resistance layer 22 is partially formed on the surface of the conductive film 12A of the second electrode 9B with a predetermined interval. Material and composition of the resistance layer 22 is similar to that of the resistance layer 20. The resistance layer 22 is formed on the surface of the

conductive film 12A with the predetermined interval. Spacers 21 are mounted on the partially formed resistance layer 22. In this embodiment, since the conductive film 12A of the second electrode 9B is exposed, the contact resistance between the conductive films 10A and 12A is reduced in comparison with that of the third embodiment.

FIG.9 is a sectional partial side view of a fifth embodiment of the sheet-like switch in accordance with the present invention. In the fifth embodiment, the resistance layers 22 are partially formed on both the conductive film 10A and 11A of the first and second electrodes 9A and 9B, respectively. Then, the spacers 21 are mounted on the resistance layers 22 of both the conductive films 10A and 12A. The methods for forming the resistance layers 22 and the spacers 21 are identical with that of the fourth embodiment shown in FIG.8.

In the fifth embodiment, since both the conductive films 10A and 12A are exposed, contact resistance between the conductive films 10A and 12A is relatively lower. On the other hand, durability of the conductive films 10A and 12A is inferior in some degree to the third or fourth embodiment because of direct contact between the conductive films 10A and 12A. Therefore, the sheet-like switch in the fifth embodiment is feasible for low frequency of operation and low contact resistance. Since the spacers 21 are formed on the resistance layers

22 which has rough surface, adherence of the spacers 21 to the surface of the conductive films 10A and 12A is increased, hence dropout of the spacer 21 is prevented.

Although the invention has been described in its preferred form with a certain degree of particularity, it is understood that the present disclosure of the preferred form has been changed in the details of construction and the combination and arrangement of parts may be resorted to without departing from the spirit and the scope of the invention as hereinafter claimed.

WHAT IS CLAIMED IS

1. A sheet-like switch comprising:

a first sheet-like electrode composed of a non-conductive flexible film having a conductive film on a surface thereof,

a second sheet-like electrode composed of a non-conductive film having a conductive film on a surface thereof facing said conductive film of said first sheet-like electrode, and

a plurality of non-conductive spacers of 50 μm or less in diameter and 15 μm or less in height mounted on at least one of said first and second sheet-like electrodes.

2. A sheet-like switch comprising:

a first sheet-like electrode composed of a non-conductive flexible film having a conductive film on a surface thereof and a conductive coating of plastics containing fine metal particles or metal oxide particles coated on said conductive film,

a second sheet-like electrode composed of a non-conductive film having a conductive film on a surface thereof and a plurality of non-conductive spacers mounted on said conductive film with a predetermined interval, and arranged facing said conductive film of said first sheet-like electrode.

3. A sheet-like switch comprising:

a first sheet-like electrode composed of a non-conductive flexible film having a conductive film of a metal or metal oxide thin film on a surface thereof, a resistance layer of plastics containing fine metal particles or metal oxide particles and transparent balls of 5 to 10 μm diameter having a thin metal film on the surface thereof coated on the surface of said conductive film and a plurality of spacers of mounted on said resistance layer with a predetermined interval,

a second sheet-like electrode composed of a non-conductive film having a conductive film of a metal or metal oxide thin film on a surface thereof, a resistance layer of plastics containing fine metal particles or metal oxide particles and transparent balls of 5 to 10 μm diameter, having a thin metal film on the surface thereof, coated on the surface of said conductive film, and a plurality of spacers mounted on said resistance layer with a predetermined interval, arranged facing said conductive film of said first sheet-like electrode.

4. A sheet-like switch in accordance with claim 3, wherein

said resistance layer on the conductive film of said second non-conductive film is partially formed on said conductive film, and said spacer is mounted on said each resistance layer.

5. A sheet-like switch in accordance with claim 3,

wherein

said resistance layer on the conductive film of said first non-conductive flexible film is formed partially on said conductive film, and said spacer is mounted on each of said resistance layer,

said resistance layer on the conductive film of said second non-conductive film is formed partially on said conductive film, and said spacer is mounted on each of said resistance layer.

6. A sheet-like switch in accordance with claim 1, 2 or 3, wherein

said non-conductive flexible film of said first sheet-like electrode and said non-conductive film of said second sheet-like electrode are transparent.

7. A sheet-like switch in accordance with claim 1, 2 or 3, wherein

said conductive film is transparent.

8. A sheet-like switch in accordance with claim 2, wherein

said conductive coating is transparent.

9. A sheet-like switch in accordance with claim 3, wherein

said resistance layer is transparent.

10. A sheet-like switch comprising:
first and second sheet-like electrodes;
and
a plurality of insulative spacers
5 interposed between said electrodes; wherein
said spacers have lateral dimensions of 50
 μm or less and a height of 15 μm or less.

11. A switch as claimed in claim 10, wherein
10 said spacers are formed of photoresist material.

12. A sheet-like switch comprising:
first and second sheet-like electrodes;
a plurality of insulative spacers
15 interposed between said electrodes; and
a protective coating comprised of
conductive particles embedded in a binding matrix
material formed upon the surface of at least one of
said first and second sheet-like electrodes.

20

13. A switch as claimed in claim 12, wherein
said coating includes a distribution of
conductive-film coated balls.

14. A method of producing a sheet-like switch wherein:

5 a layer of photoresist is deposited upon the surface of a sheet-like electrode and is photolithographically defined to form a plurality of insulative spacers having lateral dimensions of 50 μm or less and a height of 15 μm or less.

10 15. A sheet-like switch constructed, adapted and arranged to operate substantially as described hereinbefore with reference to and as shown in Figures 1 to 9 of the accompanying drawings.